

## High quality power supply

- Delivered by SVM digital modulation (Space Vector Modulation).
- Adapted to supply new IT loads with a leading power factor up to 0.9 without derating.
- With sinusoidal voltage for non-linear loads (Crest Factor 3:1).

## High availability

- A fault tolerant architecture with redundancy of basic functions, such as the ventilation system.
- A variety of architectures for parallel operations, to deal with redundancy, management and changes in power output.

## Easily integrated equipment

- An IGBT rectifier which virtually eliminates harmonic distortion without filters, thus removing any stress on your power supply network.
- Reduced current consumption due to an input power factor of 0.99 without derating constant in every situation.
- The ideal solution for grouping with generator sets without using an excessively large generator.

## Battery availability at all times

- An innovative load algorithm which adapts to the environmental conditions and the condition of the battery to increase its life.
- A highly-developed monitoring system, capable of locating and correcting any problems interacting with the charging device.

## Cost effective equipment

- A compact unit for a smaller footprint.
- An IGBT rectifier, which reduces the size of the infrastructure (transformer, generator set and distribution)
- The ENERGY SAVER function, staying in on-line mode and keeping the redundancy required.

## User-friendly operation

- A control panel with graphic display for more ergonomic operation.
- An array of "com-slot" plug-in communication interfaces, for upgrading your operating requirements.

## Simplified maintenance

- An advanced diagnostic system.
- A remote access device connected to the remote maintenance centre.
- Easy access to subassemblies and components, facilitating tests and reducing maintenance time (MTTR).

## Remote monitoring

- Easy remote monitoring via web browser or via customer's supervision systems (web, intranet, extranet...).
- Very open connectivity (Modbus/Jbus, Jbus tunnelling, LAN...).



DELPHYS 121 B 1 CAT

Your protection  
for

- > Data centre
- > Industry
- > Telecommunications
- > Processes



## High quality power adapted to new IT loads

The SVM digital modulation (Space Vector Modulation) fitted to the transformer integrated downstream of the inverter allows supply to your installations with:

- precise voltage even when the load between phases is completely unbalanced,
- stable output voltage during significant and quick variations in loads ( $\pm 2\%$  in less than 5 ms),
- sinusoidal THDV output voltage  $< 2\%$  with linear loads and  $< 3\%$  with non-linear loads,

- active power without de-rating, for loads with a lagging power factor and up to 0.9 leading,
- a high short-circuit capacity, up to  $4 I_n$ , which facilitates the selection of protective devices for selectivity in the downstream distribution,
- an isolation transformer is installed on the inverter output to ensure complete galvanic isolation between DC circuit and load output.

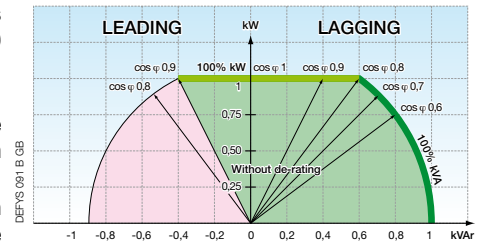

## DELPHYS MP elite easy to integrate into your electrical network

### A "clean" IGBT rectifier

It eliminates any disturbance on the upstream network (source and distribution).

- The cutting rectifier guarantees the supply of current with an exceptionally low rate of harmonic distortion: THDI  $< 2.5\%$ .

### A consistent rectifier

- The performance of the IGBT rectifier is independent of frequency variations that could be produced by the generating set.
- The power factor and THDI at the rectifier input are constant whatever the battery charge status (continuous voltage level) and the load rate of the UPS.

### An economical IGBT rectifier

- The power factor upstream of the rectifier: 0.99, reducing the kVA used by 30% when compared with conventional technology. The reduction in input current results in a saving in terms of the scale of sources, cables and protective devices.

- Rectifier capabilities:
  - low upstream THDI,
  - gradual, timed restarting,
  - possibility of suspending battery recharge
 when operating with a generator set, allow the impact caused when the generator set is engaged and the energy used to be reduced, along with the footprint.



## Guaranteed available back-up time

### EBS Technology (Expert Battery System)

This exclusive feature prolongs battery life.

- It carries out the charge according to an algorithm which adapts to the environment and the condition of the battery.
- It reduces corrosion and drying out of the separators often caused by permanent floating loads.
- It reduces the residual ripple of the current, one of the causes of premature battery wear.

### BHC Technology (Battery Health Check)

Guaranteed battery availability:

- the battery and DC circuit are regularly tested automatically and the operator is notified of their condition,
- optional **BHC** function tests analyse the following parameters: current by branch, voltage by segment or block. In case of drift, the interactive system automatically takes corrective charging measures. If the drift continues, an alarm with the location of the failure (branch, segment or block) allows the necessary preventative repairs to be made.



## Parallel systems

In order to meet the most demanding availability requirements, and the need for the installation to be flexible and upgradable, up to 6 **DELPHYS MP elite** can run in parallel.

- **DELPHYS MP elite** modular, development without constraint.

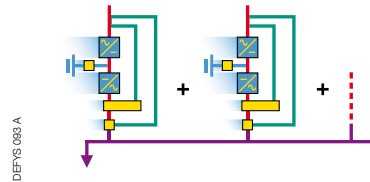

- **DELPHYS MP elite** centralised bypass, progressive development.

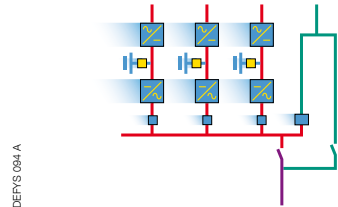

- **DELPHYS MP elite** redundant bypass, for greater availability.

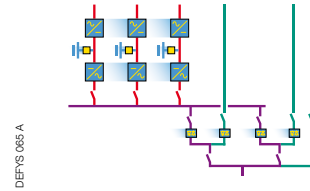

- **DELPHYS MP elite** double bypass, to simplify operation.

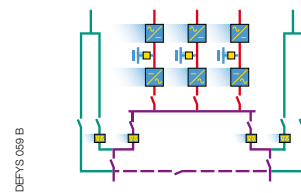

- **DELPHYS MP elite** multi bypass, to separate application types.

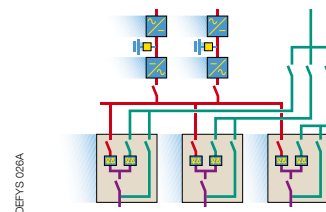

- **DELPHYS MP elite** a twin channel architecture with Static Transfer Systems.

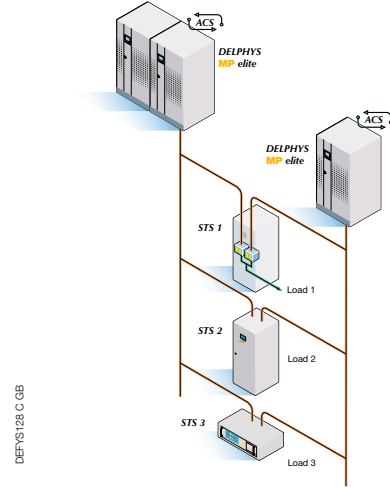

## Battery

The key element in a UPS

The Socomec batteries are selected for their quality manufacture, robustness and ability to restore power when needed.

## Standard equipment

- Slots for 7 communication cards.
- Protection backfeed: detection circuit.
- Standard interface:
  - 3 inputs (emergency stop, generating set, battery protection),
  - 4 outputs (general alarm, back-up, bypass, preventative maintenance needs).

## Accessories

- **BHC** battery unit monitoring.
- **EBS** (Expert Battery System).
- Graphic touch screen.
- **Flywheel** compatible.
- **ACS** function for synchronisation with an external source.
- Reinforced IP protection degree.
- Ventilation filters.
- Ventilation control.

## Communication options

- Remote control panel.
- ADC (Advanced Dry Contacts) data input and output by dry contacts.
- RS232, RS422, RS485 serial port JBUS/MODBUS or PROFIBUS.
- **MODBUS TCP** interface (JBUS/MODBUS tunneling).
- **NET VISION** interface for the LAN Ethernet network.

## Remote maintenance

- **T.SERVICE** for continuous 24/7 monitoring the SOCOMECS UPS maintenance service.

## Graphic display

Design adapted to the user: control panel with LEDs and LCD display.



## Graphic touch screen (GTS)

The operator has access to the control functions with only a few intuitive touches of the screen.

Direct access zones to sub-unit menus

Operating mode icons

Help menu for correct operation

UPS load rate (bar graph)

Quick access to each installation module

Access to installation mimic panel

Status bar

Preventative maintenance request

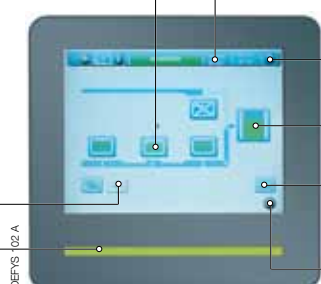

## UPS and batteries

A compact and integrated system.

UPS	DELPHYS MP elite	Battery for back-up time			
		10 minutes		15 minutes	
		W mm	Weight kg	W mm	Weight kg
UPS power kVA/kW	Weight kg				
60/48	700	800	810	800	1200
80/64	700	800	1200	800	1270
100/80	820	800	1230	800	1310
120/96	820	800	1310	1600	2390
160/128	980	1600	2390	1600	2530
200/160	980	1600	2460	2400	3590

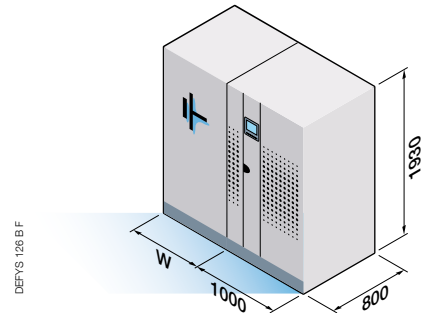

## Central bypass cabinet

Coupling cabinet including the central static switch and the maintenance bypass.

Power <sup>(1)</sup> kVA	W mm	Weight kg
60	800	300
80	800	300
120	800	300
200	800	300
250	800	370
300	800	370
400	800	370
500	800	370
800	1000	420
1200	1300	600

(1) For other power ranges, please consult us.

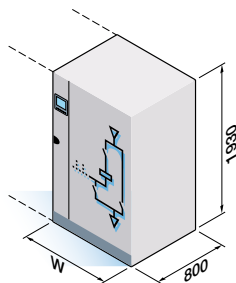

## On line double conversion

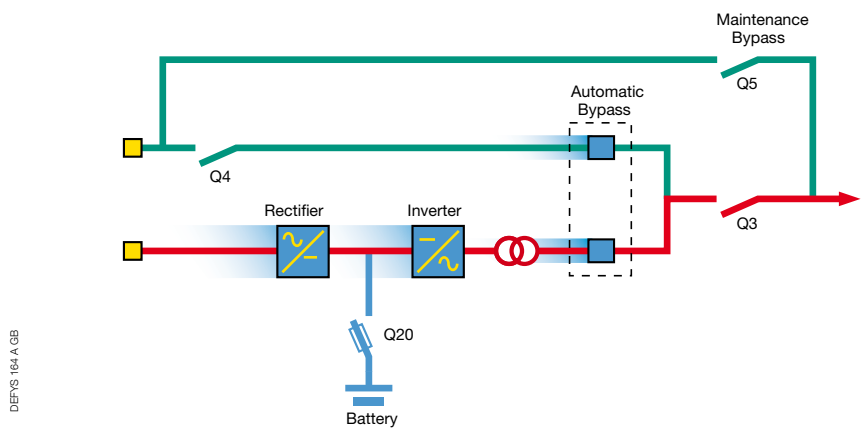

## Technical data

### RECTIFIER INPUT

Technology	PFC - IGBT
Voltage	three-phase 380 V - 400 V - 415 V <sup>(1)</sup>
Acceptable tolerance	340 to 460 V
Frequency	50 - 60 Hz (45 to 65 Hz)
Power factor	0.99 constant
Distortion rate	THDI: 2.5 % without filter

### OUTPUT

Voltage (configurable)	three-phase + N 380 V - 400 V - 415 V <sup>(1)</sup>
Voltage tolerance static load	< 1 %
dynamic load conditions from 0 to 100 %	± 2 % in 5 ms
Voltage distortion rate	THDU < 2 %
Acceptable crest factor without de-rating	3:1
PF acceptable without de-rating	lagging to 0.9 lead.
Frequency (configurable)	50 - 60 Hz
Autonomous frequency tolerance	± 0.2 %
Overload	1 min: 150 % 10 min: 125 %

### EFFICIENCY

Global <sup>(2)</sup>	94 %
In ECO-MODE configuration	98 %

### ENVIRONMENT

Noise level (ISO 3746) <sup>(2)</sup>	67 dBA
Compliance to standards safety	IEC62040-1-2/IEC60950
EMC technical data	IEC 62040-2 IEC 62040-3
Classification according to IEC 62040-3	Voltage Frequency Independent, on-line double conversion VFI - SS - 111

(1) Three-phase 220-230-240 V on demand. - (2) As per power range.

## Bypass transformer

For galvanic isolation.

Power <sup>(1)</sup> kVA	W mm	Weight kg
60	600	400
80	600	450
120	600	550
200	800	850
300	1000	1250
400	1200	1500

(1) For other power ranges, please consult us.

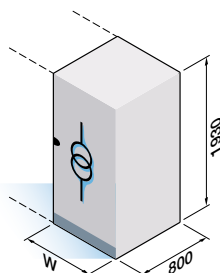

(1) For other power ranges, please consult us.